

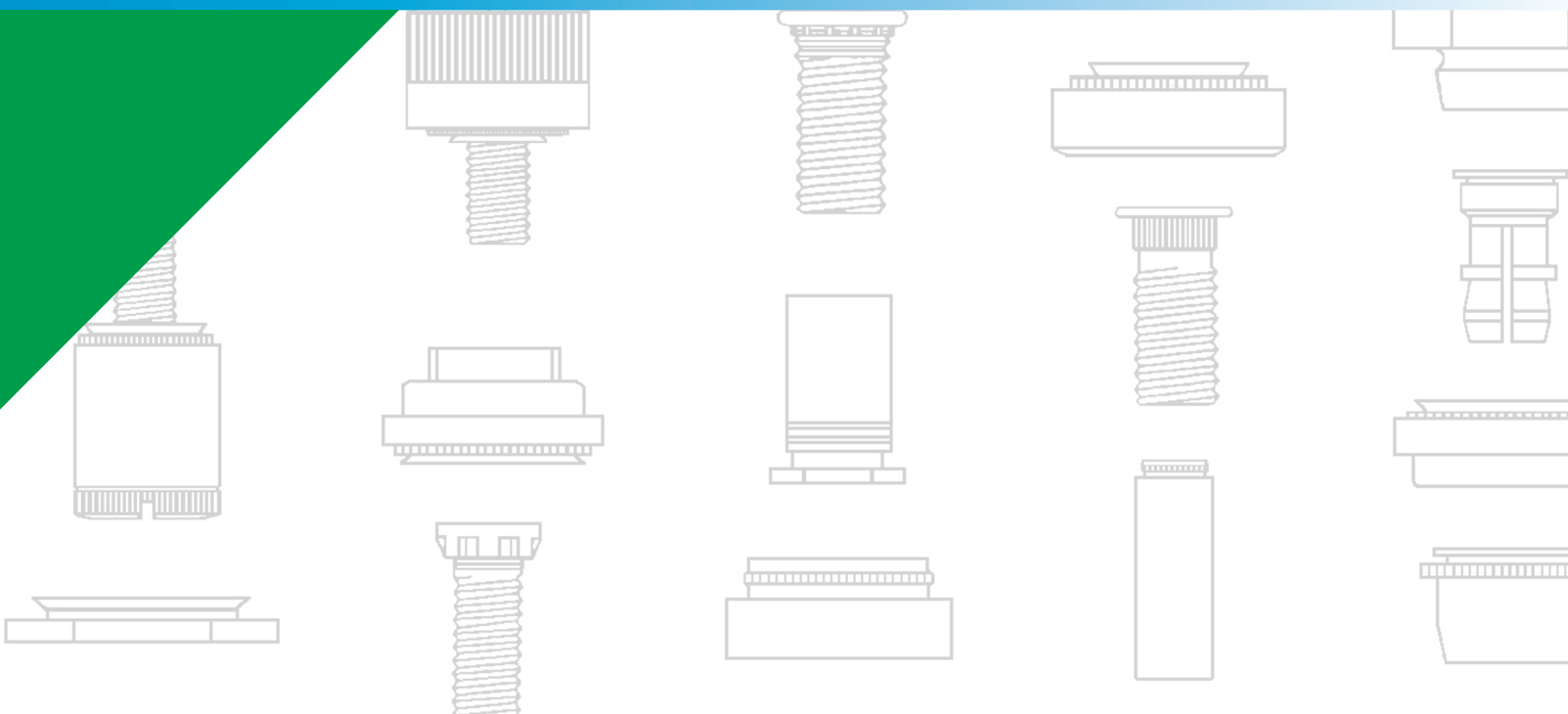

The Self-clinching Fastener Handbook



contents

Brief fastener history	3
How, why and where self-clinching works	4
Reliability in service	5
Anatomy of self-clinching	6
Types of self-clinching fasteners	7
Importance of quality	8
Installation procedure	9
Installation problems and solutions	10-11
Common Design Challenges	12
Other considerations	13
Questions and Answers	14
Glossary of terms	15
Identification Trademarks	16

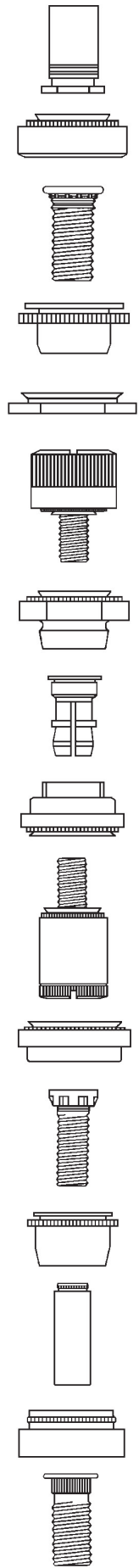

© 2018 PennEngineering.
PEM® is a brand name and a registered trademark for fasteners manufactured exclusively by PennEngineering.



the idea

that revolutionized production fastening



When K.A. Swanstrom founded Penn Engineering & Manufacturing Corp. in 1942, he did so with a revolutionary

new product: an easy-to-install, self-clinching fastener that provides load-carrying threads in metal sheets too thin to be tapped.

At first, Mr. Swanstrom produced his innovative design with four machines in a Doylestown, Pennsylvania garage. This simple operation soon gave way to a modern facility in Danboro, Pennsylvania as manufacturers and engineers alike recognized the benefits of self-clinching fasteners. They not only reduced time, labor, weight and inventory on many assembly jobs, but they also opened up a whole new world for engineers and

designers, making a wide assortment of thin-metal designs possible for the first time.

Industry-wide acceptance led to earnest production of self-clinching fasteners shortly after World War II. As industry's need to hold together ultra-thin and ultra-light metals grew, so did the product line. Over the years the original self-clinching fastener design evolved to meet hundreds of new design applications.

Today, nuts, studs, spacers, standoffs, access hardware, and other components are used worldwide by a variety of manufacturers, including producers of telecommunication, computer, medical, automotive, and aerospace equipment and systems.



Advantages of self-clinching fasteners:

- Provide strong threads in metal as thin as .012"/0.3 mm.
- Installs into a plain, round hole.
- Installed using any parallel acting squeezing force.
- Provide high pushout and torque-out resistance.
- Do not require special hole preparation, such as chamfering and deburring.
- Reverse side of metal sheet remains flush.
- No retapping necessary after application.
- Low installed costs.



how, why & where to use self-clinching fasteners

broadly defined, a self-clinching fastener is any device, usually threaded, that when pressed into ductile metal, displaces the host material around the mounting hole, causing it to cold flow into a specially designed annular recess in the shank or pilot of the fastener. A serrated clinching ring, knurl, ribs, or hex head prevents the fastener from rotating in the host material once it has been properly inserted (see page 6). Thus, self-clinching fasteners become a permanent part of the panel, chassis, bracket, or other item into which they are installed.

They also have greater reliability and more holding power than extruded/tapped or stamped threads. They are used chiefly where good pullout and torque loads are required in sheet metal that is too thin to provide secure fastening by any other method. Even if the

sheet is thick enough to sustain tapping, it may actually be more economical to use self-clinching fasteners with gaugeable threads. They can be installed during fabrication to eliminate loose hardware during final assembly. In fact, the use of self-clinching fasteners often will allow the use of a thinner sheet. Because of their compact design and low profile, they provide for a neat appearance, too.

As a rule, a self-clinching fastener should be specified whenever a component must be readily replaced and where “loose” nuts and hardware won’t be accessible. If it appears that the attaching “nuts” and “screws” can’t be reached after a chassis or cabinet is assembled, self-clinching fasteners can be installed during metal fabrication and can simplify and expedite component mounting and assembly operations, including those performed in the field.

DESIGN FOR MANUFACTURE AND ASSEMBLY

Self-clinching fasteners help designers meet DFMA parameters which include:

- Fewer parts to handle. Hardware such as washers, lock washers, and loose nuts are no longer required in final assembly.
- Fewer assembly steps. Since the task of hardware installation is done during fabrication, the number of steps required for final assembly is reduced.
- Less total assembly time. Fewer parts and less steps mean shorter assembly time.

All of which lead to shorter time to market, improved quality through assembly simplification, and reduced overhead.

SELF-CLINCHING FASTENERS REQUIRE:

- Ductile panel material softer than the fastener. (Generally a 20 point difference on the Rockwell B scale is required). See tables on page 6.
- Adequate sheet thickness.
- Pre-punched holes.
- Access to both sides of the sheet for installation.
- An insertion press with adequate throat depth to reach the installation point.

If these conditions can be met, then self-clinching fasteners are the best solution for strong, clean, permanent threads in thin sheet metal. If material is not ductile enough, see “Fasteners for Non-ductile Materials” on page 13.

SPECIAL NOTE FOR INSTALLING INTO STAINLESS STEEL SHEETS

One of the very basics of self-clinching is that the fastener must be harder than the host sheet. Only then will the fastener perform as intended. This is particularly challenging when installing fasteners into stainless steel sheet metal.

If your application requires that the fastener clinches into stainless steel, be sure you use the fasteners specifically designed for this purpose. Consult PEM® Bulletin SS for information on these types of fasteners.

reliability in service of a self-clinching fastener

The reliability of a self-clinching fastener in service depends on many factors, beginning with a properly sized hole, the thickness and hardness of the host panel, proper installation and design of the fastener, and the application where the fastener is used.

There are three tests applicable to a self-clinching fastener to determine its reliability in service. The first, called torque-out, determines the fastener's ability to resist rotation within the panel. This test often is made at the head of

the fastener often with values exceeding the ultimate torsional strength of the mating screw or nut.

RELIABILITY FACTORS:

- Properly sized hole
- Sheet thickness
- Sheet hardness
- Proper installation
- Quality of fastener

A second reliability measure is pushout. Pushout values indicate the axial resistance of a fastener to remove it from the sheet opposite to the direction from which it was installed, and should be roughly 5 to 10% of the force used to install the fastener.

A final test is pull-through.⁽¹⁾ Pull-through is the resistance of a fastener to pulling through the metal sheet when a clamping torque is applied.

General pushout and torque-out values for PEM® brand self-clinching nuts.⁽¹⁾

(unified and metric data)

Thread Size	Test Sheet Material																	
	Type S Nut Installed Into 5052-H34 Aluminum						Type S Nut Installed Into Cold-rolled Steel						Type SP Nut Installed Into 300 Series Stainless Steel ⁽²⁾					
	Installation		Pushout		Torque-out		Installation		Pushout		Torque-out		Installation		Pushout		Torque-out	
	(lbs.)	(kN)	(lbs.)	(N)	(in.lbs.)	(N-m)	(lbs.)	(kN)	(lbs.)	(N)	(in.lbs.)	(N-m)	(lbs.)	(kN)	(lbs.)	(N)	(in.lbs.)	(N-m)
2-56 M2	1500-2000	6.7-8.9	90	400	10	1.13	2500-3500	11.2-15.6	125	550	15	1.7	8000-10000	35.6-44.5	165	725	17	1.92
4-40 M3	1500-2000	6.7-8.9	90	400	10	1.13	2500-3500	11.2-15.6	125	550	15	1.7	8000-10000	35.6-44.5	165	725	17	1.92
6-32 M3.5	2500-3000	11.2-13.5	95	400	17	1.92	3000-6000	13.4-26.7	130	570	20	2.3	8500-10500	37.8-46.7	170	755	24	2.7
8-32 M4	2500-3000	11.2-13.4	105	470	23	2.6	4000-6000	18-27	145	645	35	4	9000-11000	40-49	180	800	37	4.18
10-32 M5	2500-3500	11.2-15.6	110	480	32	3.6	4000-9000	18-38	180	800	40	4.5	9500-11500	42.3-51.2	230	1025	45	5.08
1/4" M6	4000-7000	18-32	360	1580	90	10.2	6000-8000	27-36	400	1760	150	17	13500	60	450	2000	150	17
5/16" M8	4000-7000	18-32	380	1570	120	13.6	6000-8000	27-36	420	1870	165	18.7	14800	66-80	470	2100	170	19

(1) Pull-through generally applies only to self-clinching studs and standoffs and is not shown in this chart.

(2) See special note about installing into stainless steel on page 4.

TORQUE-OUT TEST

Torque-out tests shall be performed from the shoulder or head side of the installed fastener. Torque shall be applied to the fastener in the manner illustrated, using a hardened test screw and washer, while firmly holding the test strip. Test screws should be of sufficient tensile strength to resist thread stripping. A minimum of two screw threads must extend beyond the fastener.

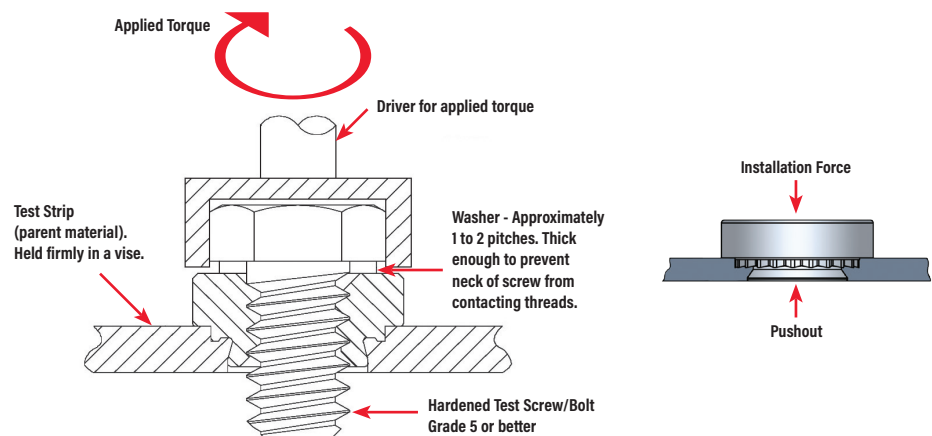

the anatomy of self-clinching

Maximum Sheet Hardness for Fastener Materials

Fastener Material	Sheet Hardness
Aluminum	<HRB 50 / HB 89
Unhardened Steel	<HRB 60 / HB 107
300 Series Stainless Steel	<HRB 70 / HB 125
Hardened Steel	<HRB 80 / HB 150
Hardened Stainless Steel	<HRB 88 (92) / HB 183 (202)

Typical Hardness of Sheet Materials

Sheet Material	Sheet Hardness
5052-H32/34 Aluminum	HRB 15-30 / HB
Cold-rolled Steel	HRB 40-75 / HB
6061-T6 Aluminum	HRB 50-55 / HB 89-96
304 Stainless Steel (Annealed)	HRB 80+ / HB 150+
HSLA Steel (does not follow typical rules)	HRB 80-85 / HB 150-169

Typical self-clinching standoff

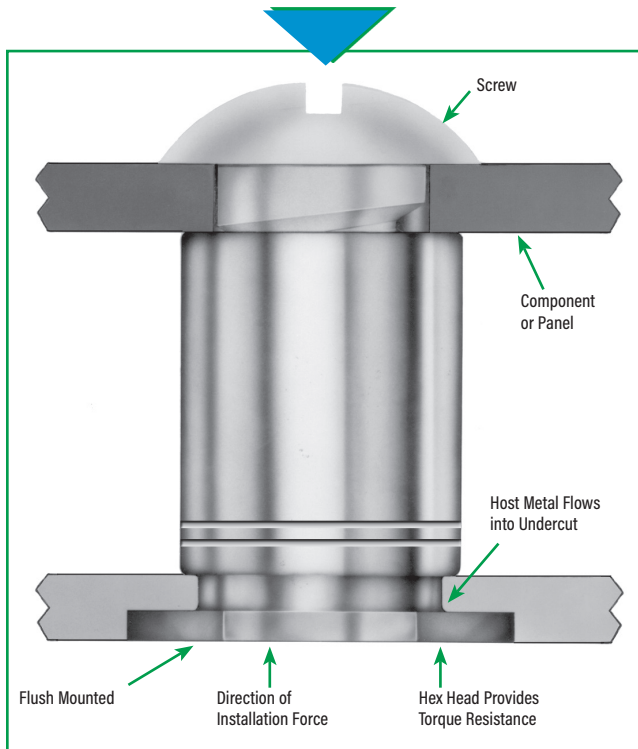

Typical self-clinching nut

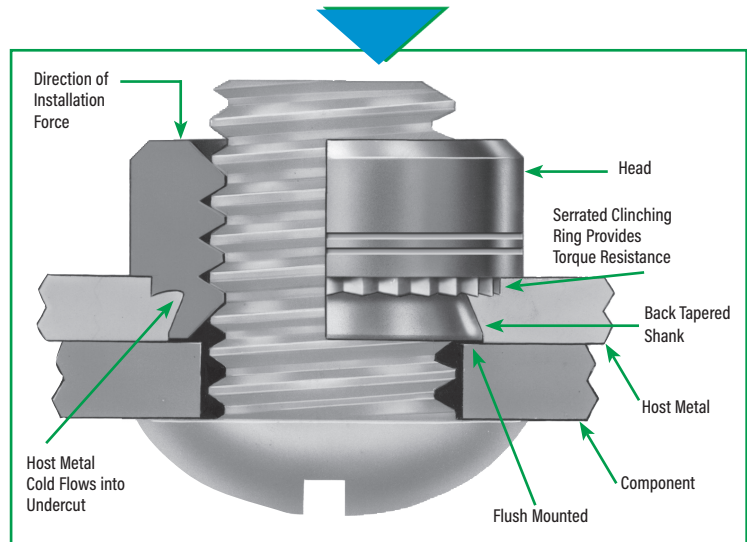

Typical self-clinching stud

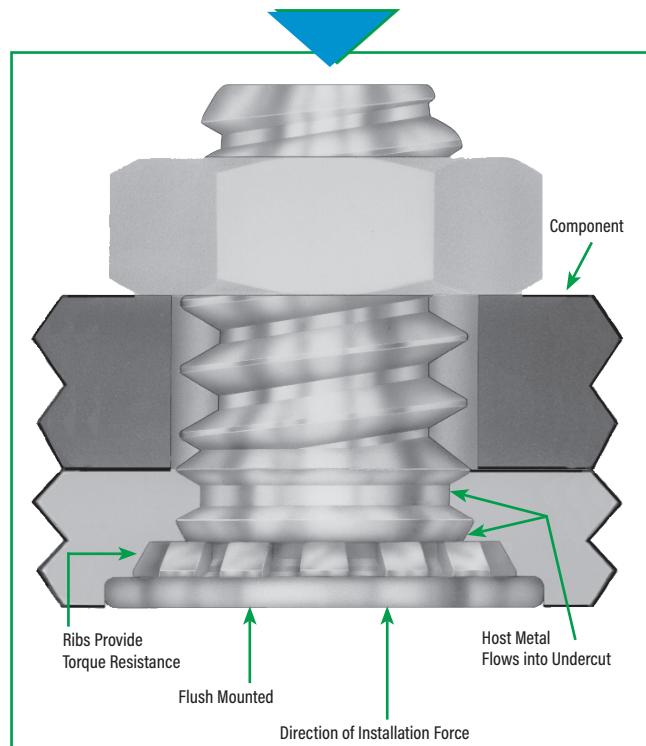

basic types of self-clinching fasteners

A self-clinching feature can be applied to many types of fasteners as shown below to combine the benefits of self-clinching with a broad range of fastener functionality. All of these self-clinching features are a variation of one on the three basic styles shown on page 6. Some unthreaded fasteners use plain round displacers because they are not subject to torsional loading and do not require an anti-rotation feature.

nuts: Nuts with thread strengths greater than mild steel screws are commonly used wherever strong internal threads are needed for component attachment or fabrication assembly.

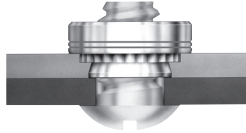

studs and pins: Threaded and unthreaded fasteners which are used where the attachment must be positioned before being fastened.



spacers & standoffs: Used where it is necessary to stack or space components away from the panel. Thru-threaded or blind types are generally standard.

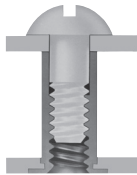

flush fasteners: These fasteners are installed completely flush within the sheet.

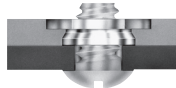

floating nuts: Compensates for mating hole misalignment by having a floating threaded element.



threaded access hardware: Generally used on enclosures where the screw must remain with the door or panel.



locking fasteners: Provide a locking feature to restrict the rotation on the screw under adverse conditions of vibration. Locking features may include metal or plastic types.

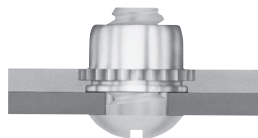

non-threaded fasteners: Allow for quick assembly or removal of components without the need for screws or additional fastening hardware.



concealed-head: Installed into milled, blind holes so that one side of the panel remains unmarred. Studs and standoffs are generally available in the concealed-head type.

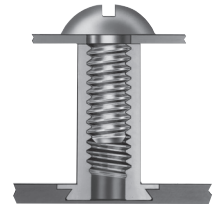

blind: Have closed ends that limit screw penetration and are useful for protecting internal components from damage by inadvertent insertion of extra long screws. Threads are also protected from damage and foreign matter.

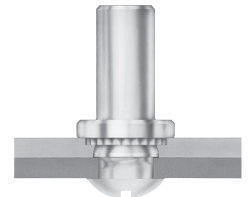

right angle: Provide strong right angle attachment points. These fasteners are a cost-effective replacement for: bent edge tabs; bent center tabs; bent flanges; angle brackets; tack welds; and loose hardware.



cable tie-mount: Provide secure attachment points for mounting wire to electrical chassis or enclosures without the problems associated with traditional mounting methods.



sheet joining fastener: Joins two sheets of metal or metal to PCB/plastic. The fastener installs smooth with the top sheet, and flush or sub-flush with the bottom sheet.



CUSTOM DESIGNS

Since there are a great many types of standard self-clinching fasteners available, it is usually possible to choose one to meet your design requirement. There are times however that a custom designed and manufactured fastener is necessary. If this is the case, PennEngineering can assist you with your requirement to provide you with the best solution to your design.



quality of self-clinching fasteners

an order request comes to the desk of the buyer or procurement individual for self-clinching fasteners. Although a review of the manufacturer's basic specifications will undoubtedly turn up a shopping list of suppliers, a purchase made on the basis of lower price alone may prove more costly in the long run.

Installed cost . . . the bottom line

When a designer investigates the desirability of using self-clinching fasteners, his calculations must offer a true picture of cost. If integral fasteners are now being welded, the cost of materials, labor and overhead must be factored into the final cost per fastener to grant an accurate comparison with the final calculated cost per self-clinching fastener. Rejects and spoilage due to failure of poorly designed fasteners will contribute to high production costs, so be certain that the fasteners actually purchased meet your engineering specifications.

There are significant variations in the materials used, manufacturing processes, quality controls and component dimensions that make the "same" product, made by different manufacturers, very different from one another.

Wire stock is used for the manufacture of

many self-clinching fasteners. Basic blanks are formed on cold headers or cold formers; subsequent operations such as piercing, drilling, tapping, thread rolling, and slotting may be required.

Self-clinching fasteners are also made from free-machining, cold-drawn, low-carbon bar stock, a variety of free-machining and cold-drawn stainless steels, aluminum and phosphor bronze. They are formed on automatic bar machines and generally have secondary operations such as slotting, tapping or lock forming.

Finishing operations such as heat-treating and plating are equally sophisticated, and quality control measures must be monitored throughout the manufacturing process.

With so many manufacturing variables to control, there are several quality areas which must be examined before choosing the supplier of self-clinching fasteners for your application.

These include:



DIMENSIONAL TOLERANCES: A self-clinching fastener requires very tight tolerances to maximize its performance. In a part that is specified with a dimension .010"/0.254 mm a variation of only .002"/0.051 mm can make a 20% difference.

THREAD FIT: A part may be specified because it meets one or more government specifications for thread tolerances. If equivalents are considered, be sure that they meet the same specifications.

LOCKING TORQUE: If applicable, be sure that parts meet the locking torque specifications required.

HEAT TREATMENT: This is a very critical quality area. Improper heat treatment can cause a fastener to fail during or after installation. Improper tempering can cause fastener brittleness causing the fastener to crack; inadequate treatment can cause fasteners to be so soft that they are literally crushed during installation.

PLATING: Plating standards set limits for preparation of the metal, plating thickness, adhesion, rust corrosion protection, hours of salt spray testing, and other operations. A poorly plated part will diminish the appearance and performance of your final product.

PERFORMANCE: The fasteners should be tested to meet the manufacturer's published performance data. In addition to basic performance testing, be sure the fastener also meets your requirements for vibration resistance, thread locking, heat, and electrical characteristics.

QUALITY CONTROL: Ensure the fastener manufacturer is ISO 9001 / QS 9000 (or other industry appropriate) compliant. This will help assure that all the above criteria is being met.

installation procedure

fast, simple installation saves time and money on the assembly line.

In just three easy steps, self-clinching fasteners can be installed with any parallel acting press that can be adjusted to optimum installation forces.

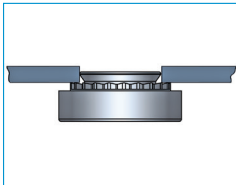

First, place the fastener into the anvil hole and place the mounting hole (preferably the punch side) over the shank of the fastener.

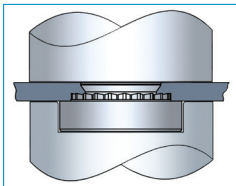

With installation punch and anvil surfaces parallel, apply squeezing force until the head of the nut comes in contact with the sheet material.

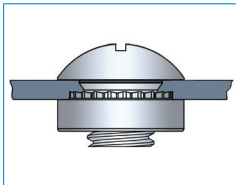

Finally, install the mating piece from the side opposite the head of the fastener.

Additional notes . . .

1. Mounting holes may be punched or drilled; they should not be chamfered or have broken edges in excess of .005"/.127 mm. Hole tolerances of +.003, -.000/+0.08 mm must generally be held. The fastener should be installed on the punch side if the sheet is .09"/2.29 mm or thicker because of the piercing break-to-die diameter. In all cases, the manufacturer's recommended "minimum centerline of hole to edge of sheet" (see page 12) distance should be observed. No deburring or countersinking is required.
2. Installation typically results in a flush surface on one side of the panel. Conversely, staked or crimped fasteners require special counterboring to obtain a one-sided flush surface.
3. When installing, the most important criterion is that the fastener must be squeezed into place with any parallel acting press.
4. Because the installation equipment generates no excess noise or pollution, the fasteners can be installed anywhere in the production process. No special facilities, ventilation equipment, or safety procedures are required.

5. When installed using the recommended squeezing force (depending on the size of the fastener and hardness of the sheet metal), there is little or no distortion of the sheet or damage to the finished surface. Fasteners generally should be installed after plating, finishing or anodizing.
6. Sheet material must be softer than the fastener. If the fastener is not hard enough, it will deform (crush) instead of cold flowing the sheet material. Some operations will locally harden a sheet, i.e., punching 300 series stainless or laser cutting a mounting hole (see note on page 4).

Fastener Installation "Dos"

- Do** provide mounting hole of specified size for each fastener.
- Do** install fastener into punch side of sheet.
- Do** make certain that shank (or pilot) is within hole before applying installation force.
- Do** apply squeezing force between parallel surfaces.
- Do** apply sufficient force to totally embed clinching ring around entire circumference and to bring shoulder squarely in contact with sheet. For some fasteners, installation will be complete when the head is flush with the panel surface.

Fastener Installation "Don'ts"

- Don't** attempt to install a 300 series stainless steel fastener into a stainless steel sheet.
- Don't** install steel or stainless steel fasteners in aluminum panels before anodizing.
- Don't** deburr mounting holes on either side of sheet before installing fasteners - deburring will remove metal required for clinching fastener into sheet.
- Don't** install fastener closer to edge of sheet than minimum edge distance indicated by manufacturer - unless a special fixture is used to restrict bulging of sheet edge.
- Don't** over-squeeze. It will crush the head, distort threads, and buckle the sheet. Approximate installation forces are listed in performance data tables. Use this info as a guide. Be certain to determine optimum installation force by test prior to production runs.
- Don't** attempt to insert fastener with a hammer blow - under any circumstances. A hammer blow won't permit the sheet metal to flow and develop an interlock with the fastener's contour.
- Don't** install screw in the head side of fastener. Install from opposite side so that the fastener load is toward sheet. The clinching force is designed only to hold the fastener during handling and to resist torque during assembly.
- Don't** install fastener on pre-painted side of panel.



installation

problems and solutions

Problem	Possible Cause	Solution
Poor holding power - fastener not seated squarely.	<ul style="list-style-type: none"> Punch and anvil faces are not parallel. Panel cocked during installation. 	<ul style="list-style-type: none"> Ensure that punch and anvil are flat and parallel and hard. Ensure that large panels are held perpendicular to punch and anvil.
Poor holding power – fasteners fall out of panel.	<ul style="list-style-type: none"> Inadequate installation force. Panel too hard for fastener material. Countersunk hole in panel. Oversized mounting hole. Some operations may locally harden a sheet, i.e., punching 300 Series Stainless or laser cutting a mounting hole. Die side of panel thicker than .093"/2.36 mm may have hole too large for fastener due to necessary punch and die clearance. 	<ul style="list-style-type: none"> Seat fastener against shoulder by applying more force or changing shut height of press. Specify appropriate fastener material for sheet hardness, i.e., stainless steel (see note on bottom of page 4). Do not countersink or deburr hole. Prepare properly sized mounting hole. Punch hole under size and ream to catalog dimensions or change tooling to punch from opposite side of panel.
Poor holding power of fastener near bend.	<ul style="list-style-type: none"> Sheet was bent after fastener was installed. This may have caused distortion of mounting hole. Hole is punched prior to bend and hole has become elongated. 	<ul style="list-style-type: none"> Bending should be done prior to installation. Punch hole after bending the sheet
Poor holding power of standoffs or studs in panel.	<ul style="list-style-type: none"> Hole in anvil too large or chamfered. 	<ul style="list-style-type: none"> Use anvil with hole per catalog dimensions.
Poor holding power – nut off center of hole.	<ul style="list-style-type: none"> Oversize mounting hole. Nut is cocked in hole and shears side of hole when installed. 	<ul style="list-style-type: none"> Punch or drill hole to specified dimensions. Check that shank of nut is squarely in hole before squeezing.

installation

problems and solutions

Problem	Possible Cause	Solution
Threads tight – sheet buckles.	<ul style="list-style-type: none"> Fastener over-squeezed. 	<ul style="list-style-type: none"> Reduce installation force.
Tight threads, cracked.	<ul style="list-style-type: none"> Shank length extends through sheet. 	<ul style="list-style-type: none"> Choose fastener with proper shank length for sheet thickness.
Fastener does not fit into hole.	<ul style="list-style-type: none"> Undersized mounting hole. 	<ul style="list-style-type: none"> Prepare properly sized mounting hole.
Fastener deforms or shears during installation.		
Sheet metal may extrude into installation tooling causing tool to stick or crack.		
Panel buckles badly with stud in .040" to .059" (1 mm to 1.5 mm) material.	<ul style="list-style-type: none"> Lack of countersink in anvil. 	<ul style="list-style-type: none"> Provide countersink in anvil to specified dimensions.
Head of flush-head stud or standoff cups.	<ul style="list-style-type: none"> Punch diameter too small or not hard and flat. 	<ul style="list-style-type: none"> Punch must be larger than head of stud or standoff and preferable equal to anvil diameter.
Edge of panel bulges.	<ul style="list-style-type: none"> Mounting hole violates specified minimum edge distance. Nut is over-squeezed. 	<ul style="list-style-type: none"> Restrain panel or bracket in fixture during installation or move mounting hole away from edge. (See page 12) Reduce installation force if possible.

Questions? Consult our Applications Engineering department at techsupport@pemnet.com



common design challenges

CENTERLINE-TO-EDGE

When installing too close to an edge, the sheet may bulge or blow out. Supporting the edge with special anvils can be used to reinforce the edges and get closer than published values indicate. Use with caution.

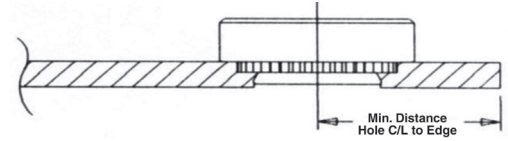

MULTI-SIDED CLOSE-TO-EDGE APPLICATIONS

All minimum centerline to edge distances given in catalog bulletins apply to one edge only. If this distance is applied on multiple sides as shown here and the edges are not supported during installation there will be significant panel distortion as shown by the dotted lines. This distortion will reduce the amount of panel material in the undercut and may significantly reduce the holding power of the clinch feature.

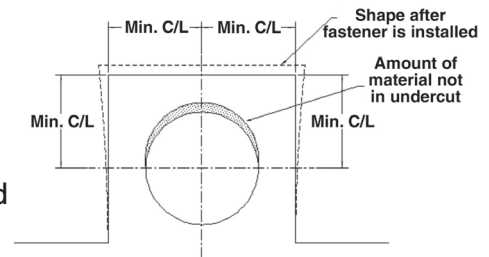

PROXIMITY TO A BEND

When installing near a bend, use the "Centerline-to-Edge" value to find the minimum distance to the outside of the bend radius. Failures that occur are different from Centerline-to-Edge situations.

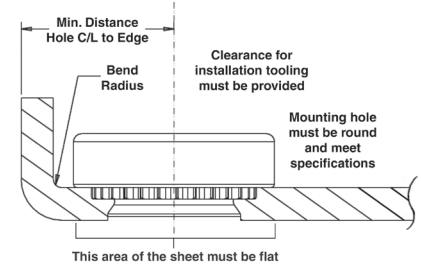

SPACING OF MULTIPLE FASTENERS

Multiple fasteners installed must be spaced far enough apart to avoid distorting each other's holes. Failures seen can include sheet distortion and "oil canning". When determining the distance between two or more fasteners, you can calculate the distance by the formula, C/L to edge + 1/2 the diameter of the second mounting hole.

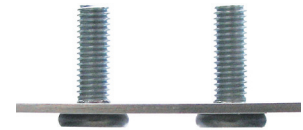

See our [Tech Sheet](#) for more information on centerline-to-edge challenges.

MATERIAL AND FINISH CONSIDERATIONS

- Do not install self-clinching fasteners after paint or powder coating. This will diminish fastener performance.
- When using steel panels, install plated fasteners after panel is plated. Otherwise install unplated fasteners into panel if entire assembly is going to then be plated.
- Do use proper alloy (A286/400 Series) stainless fasteners in stainless steel sheets. 300 Series fasteners do not provide adequate differential hardness for best performance.
- Anodizing complete aluminum assemblies after installing aluminum fasteners may cause slight color differences between fasteners and panel.
- Beware of processes such as hard coat anodizing and nitriding that might increase panel hardness. This might make it more difficult to install self-clinching fasteners.

See our [Tech Sheet](#) for more information on surface finishing sheet metal assemblies.

other considerations

AUTOMATED ASSEMBLY

Since all self-clinching fasteners must be squeezed into place, any press or vise that provides the necessary parallel force may be used to install them.

An automated press should be considered for high volume installations. These presses are specifically designed to feed self-clinching fasteners automatically into punched or drilled holes in sheet metal, seating them correctly with a parallel squeezing force. Feeding rates are five to six times faster than manual insertions, and installation force is adjustable to compensate for variations in thickness and hardness of the sheet and the height of the fasteners.

Our equipment capabilities incorporate “smart” tooling and software, automation, robotics integration, and in-die installation with our in-die fastener feeding system which brings new dimensions to stamping capabilities and incorporates the latest technologies to deliver the performance that is needed to compete in the highly competitive stamping industry. It eliminates the secondary operations typically required for fastener insertion, thus reducing overall labor costs, improving part quality and dramatically improving production efficiencies.



Haeger 824 OneTouch-4e Lite.



PEMSERTER® In-Die fastener feeding system.

FASTENERS FOR NON-DUCTILE AND ONE-SIDE ACCESS INSTALLATION

Self-clinching fasteners are designed to be installed into sheet metal panels only when both sides of the sheet are accessible. For applications that do not meet this criteria, PennEngineering offers other possible solutions. These include:

ATLAS® style blind threaded inserts (rivet nuts) provide strong threads in applications where only one side of the assembly is accessible for installation. These fasteners can also be used in most non-ductile material applications.



A broaching fastener is any knurled shank fastening device that is pressed into a punched or drilled hole to provide a strong threaded attachment point in a non-ductile material.

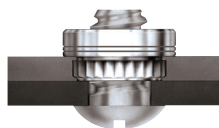

Flare-mount fasteners offer a combined broach/flare feature for even greater pullout performance in P.C. Board materials.

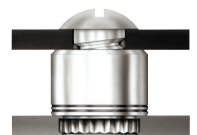

ReelFast® SMT fasteners mount to P.C. boards in the same manner as other surface mount components prior to the automated reflow solder process.

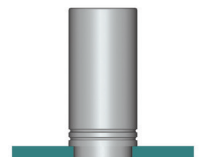

VariMount® bonding fasteners are assemblies comprised of standard PEM® fasteners mounted permanently into base plates. The assembly can then be fastened to assorted panel types in a variety of ways.



answers to the ten most frequently asked questions about self-clinching fasteners

Q Does the shape of the self-clinching fastener change during installation?

A No, the fastener does not deform in any way. There is no flaring, crimping, swaging, peening or riveting necessary.

Q What holds the fastener in the sheet?

A The squeezing force on the fastener causes the sheet material beneath the head to cold flow into the back-tapered shank or undercut of the fastener securely locking it in place.

Q Do I need special equipment to install self-clinching fasteners?

A No. Self-clinching fasteners are installed using any type of parallel acting press which will squeeze the fastener in place.

Q Won't these fasteners fall out, twist out, or spin in their mounting holes if I tighten down too hard?

A No. Typical torque-out values are generally quite high compared to the rotational force that will be put on them. In fact, for most quality self-clinching nuts, the screw will fail before the nut rotates in the material.

Q I would like to replace some of the welded fasteners I now use in my stainless steel fabrications. Is there a self-clinching fastener that will go into a stainless steel sheet?

A Yes. Self-clinching fasteners for stainless steel applications are available. These fasteners are generally made from specially hardened stainless steel and will install into sheets up to HRB 88 in hardness.

Q When using self-clinching fasteners, what are my panel requirements?

A Generally, there are two basic requirements. First, the panel must be a ductile material softer than the fastener which is going into it. Second, the panel must meet the minimum sheet thickness required by the particular fastener. Some self-clinching fasteners can be installed into sheets as thin as .020"/0.51 mm, but generally .030"/0.76 mm or .040"/1 mm is the minimum sheet thickness necessary.

Q Is there a maximum sheet thickness I should be concerned with before specifying self-clinching fasteners?

A Generally, there is no specified maximum thickness for sheets. However, because of their special design and function, a few fastener types do specify a thickness range which includes a maximum.

Q I notice some of the fasteners have a hexagonal shaped head. Do I have to punch a hexagonal mounting hole to install these?

A No. All self-clinching fasteners are installed into a round punched or drilled hole. A hexagonal head will cause the sheet material to cold flow around the head to provide high torque-out resistance. The hex head will be flush in the sheet when installed.

Q Can I install these blind, from one side, if I don't have access to both sides of the sheet?

A Generally, you must have access to both sides of the sheet to properly install self-clinching fasteners. However, there are some 1/4"/M6 or larger nuts which can be drawn in from one side using an impact-torque wrench. For information on blind threaded inserts for one sided access installation go to www.pemnet.com.

glossary

of terms

Anvil - An insert, either solid or hollow, which is used on the underside of a panel to resist the installation force.

Blind - A hole, usually threaded, which is open from only one end.

Broaching - The act of cutting a shape in any object by using a mandrel of a similar shape. As applied to fasteners, the way a knurled shank "broaches" its way into the mounting hole.

Captive - The ability of a fastener to remain securely attached to a panel.

Captive screw - See: panel fastener.

Chamfer - A beveled edge or corner.

Cold flow - The movement of a ductile material under pressure.

Concealed-head - A type of fastener which, when installed, is completely hidden when viewed from the reverse side.

Counterbore - That portion of the axial length of which is drilled to a larger diameter than the remaining portion of the part.

Ductile - Metal which is not brittle and can be easily formed or bent.

Floating - The ability of a fastener to move in a direction parallel to the mounting panel and allow for mating hole misalignment.

Flush - The ability of a fastener to be contained completely within the thickness of a panel. Also refers to the absence of a protrusion above the surface of the panel.

Head - The portion of a fastener which forms its largest diameter.

Installation force - A term expressed in pounds, tons, or newtons applied axially to a self-clinching fastener to achieve proper installation.

Interference fit - The insertion of one member into another whose diameter is slightly smaller than the part being inserted.

Knurled clinching ring - The displacer portion of a fastener which has corrugations and is used to develop torque resistance when installed in sheet metal.

Locking element - A device employed to restrict rotation of a threaded member while operating in adverse environments, such as vibration and temperature. The nut-locking element provides prevailing locking torque to the mating screw.

Minimum distance - The minimum distance from the center of a fastener mounting hole to the nearest edge of a panel which will keep the edge from deforming. This distance may be reduced by suitable fixturing or increasing thickness of panel material.

Minimum sheet thickness - The thinnest section of a panel, usually measured in thousandths of an inch or millimeters, into which a fastener may properly be installed. The same fastener may be installed in panels having any thickness greater than minimum.

Mounting hole - A properly-sized round opening in a panel to receive the shank of a self-clinching fastener.

Panel fastener - A threaded screw which is held captive to a panel and which, when disengaged from its main nut, remains fixed to that panel.

Pin - A captive post that extends from a panel.

Plunger assembly - A spring-loaded device used for latching or indexing purposes.

Positive stop - A visual indication that the proper depth of penetration of the knurled ring has occurred or when the "head" is in contact with the top surface of the panel. Synonym: shoulder.

Pull-through - The resistance of a fastener to a force applied in the same direction to which it was installed.

Punch - A movable insert, either solid or hollow, which applies an installation force to the top of the fastener.

Pushout - The force required to remove a fastener from a panel in a direction opposite to the way from which it was installed. Note: Pushout is expressed in pounds or newtons.

Rockwell hardness - A relative measure of hardness. Rockwell C Scale is used for hard materials, Rockwell B for softer materials, such as sheet metal.

Self-clinching - The method by which a fastener is securely attached to a sheet of ductile material by causing the material to cold flow under pressure into an annular recess of the fastener thereby securely locking it in place.

Self-locking - A locking element, formed as an integral part of a fastener, which provides force to restrict the rotational movement of a threaded member.

Shank - The portion of a fastener, which is slightly smaller than the fastener's mounting hole and provides a positive location for the fastener in the hole. A shank also incorporates an annular groove which becomes filled with panel material as the fastener is installed, and the retention of this material provides pushout resistance.

Shank length - The actual length of that portion of a fastener which is embedded in the panel material.

Shoulder - The surface area of a fastener which contacts the top surface of the sheet material. See: positive stop.

Spring-loaded - A device having a separate moveable component that is biased in one direction by a spring.

Standoff - A tubular device, usually threaded, for spacing or stacking components.

Stud - A male threaded captive post that extends from a panel.

Swaging - An operation whereby a reduced diameter of a fastener is deformed to secure it to a panel. Note: the antonym of swaging is self-clinching where the panel material is caused to deform.

Thread class - A measure of clearance or fit between the screw and the nut taken at the pitch diameter.

Threaded insert - A threaded device which is installed in a panel material.

Through hole - A hole, threaded or unthreaded, which transverses the entire length of a part and is usable from either end.

Tolerance - The absolute amount of maximum or minimum dimensional deviation allowed that will not affect the performance of a mechanical part.

Torque-out - The amount of torque necessary to spin the fastener out of the sheet. This is torque applied to the fastener. No axial load is applied.

Torque-through - The amount of torque necessary to fail the fastener in axial load.

Undercut - The reduced diameter of a fastener which receives sheet material when a fastener is installed. Depending on the type of fastener, may be rectangular or back tapered in shape.

*Expanded list of terms can be found on our web site
www.pemnet.com*



PEM® fastener identification trademarks

To help you identify genuine PEM® brand fasteners, most are marked by one of our registered trademarks. Genuine PEM brand fasteners can only be purchased from one of our authorized worldwide distributors. For a complete list of these distributors, check our web site: www.pemnet.com.



PEM® Dimple - U.S. Trademark Reg. #1,089,546

CFHA, CFHC, CHA, CHC, FH, FH4, FHA, FHL, FHLS, FHP, FHS, FHX, HF109, HFG8, HFE, HFH, HFHB, HFHS, HFLH, HSCB, KFH, KSSB, MPP, PF10, PF30, PF31, PF32, PF50, PF51, PF52, PF60, PF61, PF62, PF11, PF11M, PF11MF, PF11MW, PF11PM, PF12, PF12M, PF12MF, PF12MW, PF7M, PF7MF, PFC2, PFC2P, PFC4, PFHV, PFK, PFS2, PSHP, SCB, SCBJ, SCBR, SF, SFK, SFP, SFW, SGPC, SKC, SKC-F, SMTPLSM, SSA, SSC, SSS, T, T4, TFH, TFHS, THFE, TK4, TKA, TP4, TPS, TPXS, and TS fasteners

PEM® Stamp U.S. Trademark Reg. #1,403,759

CLS, CLSS, H, HN, HNL, PSHP, S, SFN, SL, SMPP, SMPS, SS, and WN fasteners



PEM® Skirted Shoulder U.S. Trademark Reg. #4,037,181

PF11, PF11M, PF11MF, PF11MW, PF11PM, PF12, PF12M, PF12MF, PF12MW, PF7M, and PF7MF fasteners



PEM® "Single Groove" mark U.S. Trademark Reg. #2,028,457

A4, BSO4, LA4, MSO4, PFC4, SO4, SP (Select sizes), and TSO4 fasteners

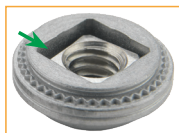

PEM® "Double Squares" mark

U.S. Trademark Reg. #1,400,893 / #3,404,061
A4, AC, AS, LA4, LAC, and LAS fasteners

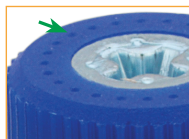

PEM® C.A.P.S.® Dot Pattern

U.S. Trademark Reg. #4,007,693
PF11PM fastener



PEM® Circle on Pedestal

U.S. Trademark Reg. #4,293,597
RAS fastener

PEM® Double Notch

U.S. Trademark Reg. #4,326,083
microPEM® SMTSO fastener

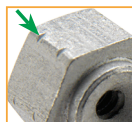

PEM® Blue Nylon Ring

PFC4, PFC2P, PFC2, PFS2, and PFK fasteners

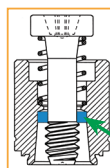

PEM® Blue Nylon Locking Element

U.S. Trademark Reg. #1,449,260
PL, PLC and CFN fasteners

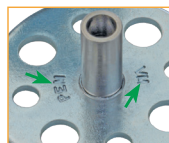
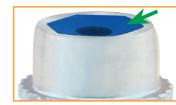

PEM VM® Stamp (Both Sides) U.S. Trademark Reg. #5,305,895

VariMount® Base Plates



PEM® SH Stamp

U.S. Trademark Reg. #5,023,068
SH fasteners

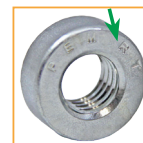

PEM® RT Stamp

S-RT fasteners

PEM® SP Stamp

U.S. Trademark Reg. #3,270,807
SP fasteners



PEM® SMPP Stamp

U.S. Trademark Reg. #5,055,266
SMPP fasteners



ATLAS® AE Stamp

MaxTite® and Plus+Tite® products

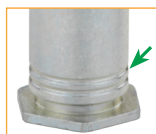
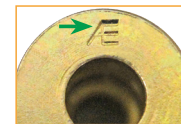

PEM® "Two Groove" mark - U.S. Trademark Reg. #2,077,226

B, BS, BSO, BSON, BSOS, CSOS, CSS, DSO, DSOS, HSR, KF2, KFB3, KFE, KFS2, KFSE, PF7M, PF7MF, SMTSO, SMTSOB, SMTPLSM, SO, SOA, SOAG, SON, SOS, SOSG, TSO, TSOA, and TSOS fasteners

All PEM® products meet our stringent quality standards. If you require additional industry or other specific [quality certifications](#), special procedures and/or part numbers are required. Please contact your local sales office or representative for further information.

Regulatory [compliance information](#) is available in Technical Support section of our website. Specifications subject to change without notice. See our website for the most current version of this bulletin.

PennEngineering®



North America: Danboro, Pennsylvania USA ▪ E-mail: info@pemnet.com ▪ Tel: +1-215-766-8853 ▪ 800-237-4736 (USA)

Europe: Galway, Ireland ▪ E-mail: europa@pemnet.com ▪ Tel: +353-91-751714

Asia/Pacific: Singapore ▪ E-mail: singapore@pemnet.com ▪ Tel: +65-6-745-0660

Shanghai, China ▪ E-mail: china@pemnet.com ▪ Tel: +86-21-5868-3688

Visit our PEMNET™ Resource Center at www.pemnet.com ▪ Technical support e-mail: techsupport@pemnet.com