

INDUSTRIAL CONICAL MOUNT SERIES: 26749 & 27595

Dimensions & Performance Characteristics

**26749 CONICAL MOUNT (30 oz.)
Dimensional Drawing**

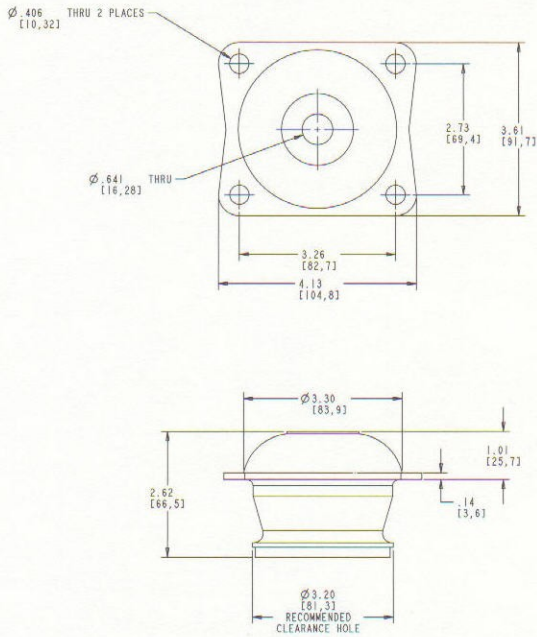

**27595 CONICAL MOUNT (29 oz.)
Dimensional Drawing**

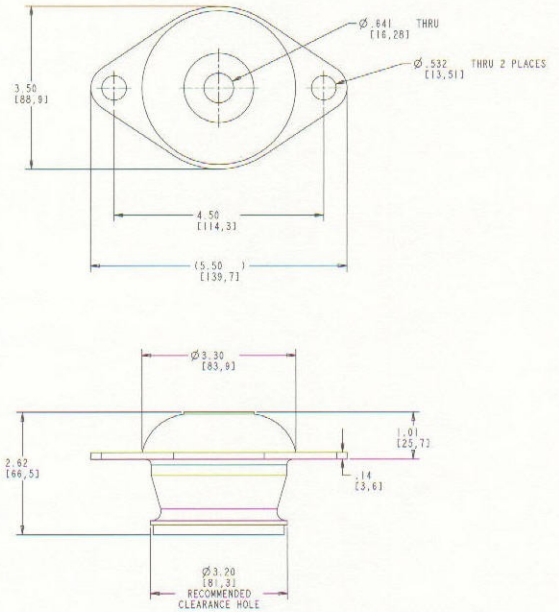

Part Number	Max. Axial Load Range (lbs.)	Color Code	Natural Frequency at Max. Load	Radial to Axial Stiffness Ratio	Bolt Size	Bolt Grade		Torque	
						SAE	ISO	ft-lbs	N-m
26749-45	463 lbs.	White	12 Hertz	1.5:1	5/8" or M16	5	8.8	180	235
26749-60	860 lbs.	Brown	12 Hertz	1.5:1	5/8" or M16	5	8.8	180	235
26749-70	1,146 lbs.	Orange	12 Hertz	1.5:1	5/8" or M16	5	8.8	180	235
27595-45	463 lbs.	White	12 Hertz	1.5:1	5/8" or M16	5	8.8	180	235
27595-60	860 lbs.	Brown	12 Hertz	1.5:1	5/8" or M16	5	8.8	180	235
27595-70	1,146 lbs.	Orange	12 Hertz	1.5:1	5/8" or M16	5	8.8	180	235